

Instruction Manual for L7

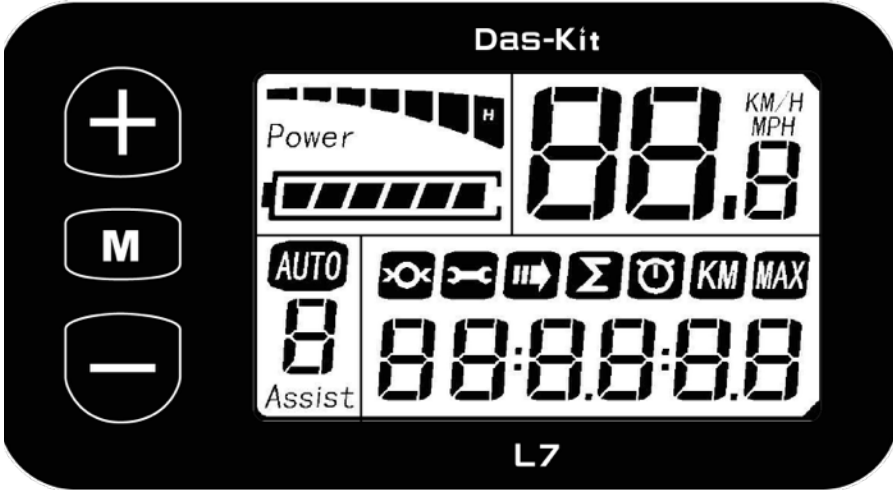

1. Instruction manual

Please read this instruction manual carefully before operating your e-bike. This manual will include installation information, setting information, and instructions for normal use.

2. Appearance and measurement

2.1 Main material and color

The display adopts black ABS material and the support is made of nylon. Please maintain the equipment in temperatures ranging from -20°C to 60°C or else the display may become damaged.

Dimension figure (unit: mm)

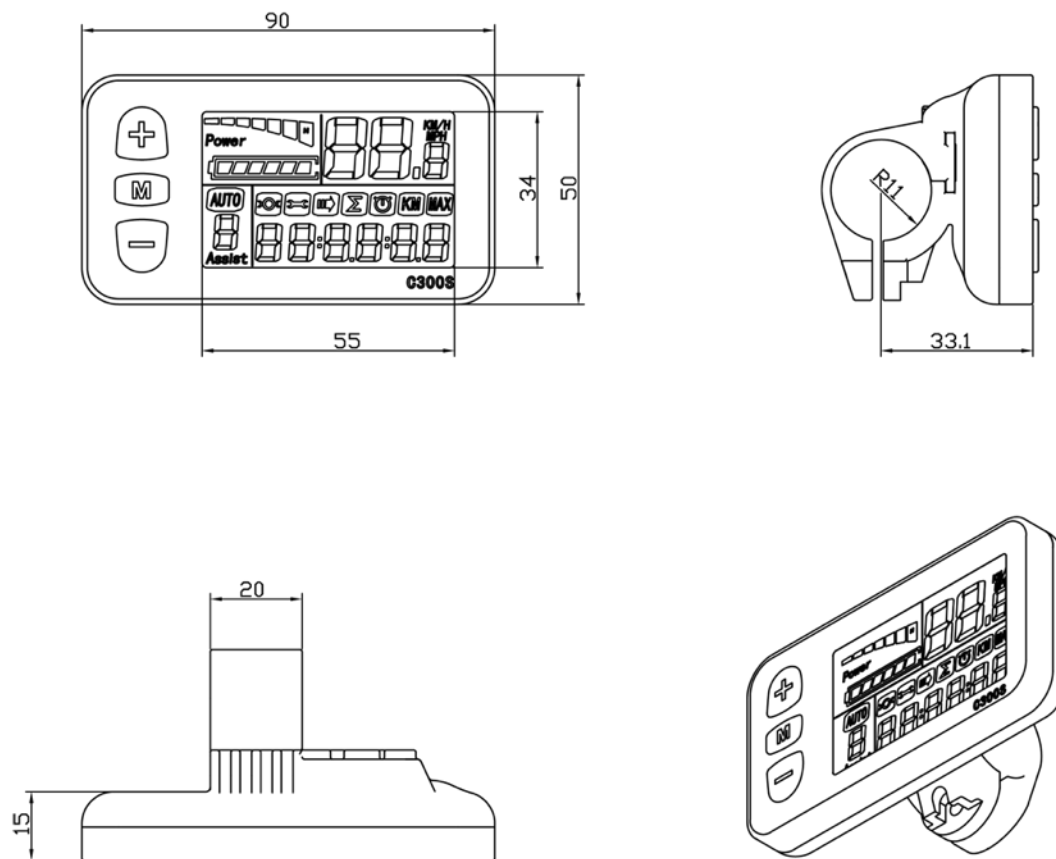

3. The Buttons

There are three buttons on the display, including “M”, “+” and “-”.

“M” presents MODE/ON/OFF.

“+” presents UP.

“-” presents DOWN.

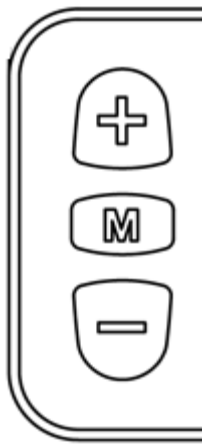

4. Function Display

4.1 FUNCTION SUMMARY

The indicated functions are as below.

1. Switch

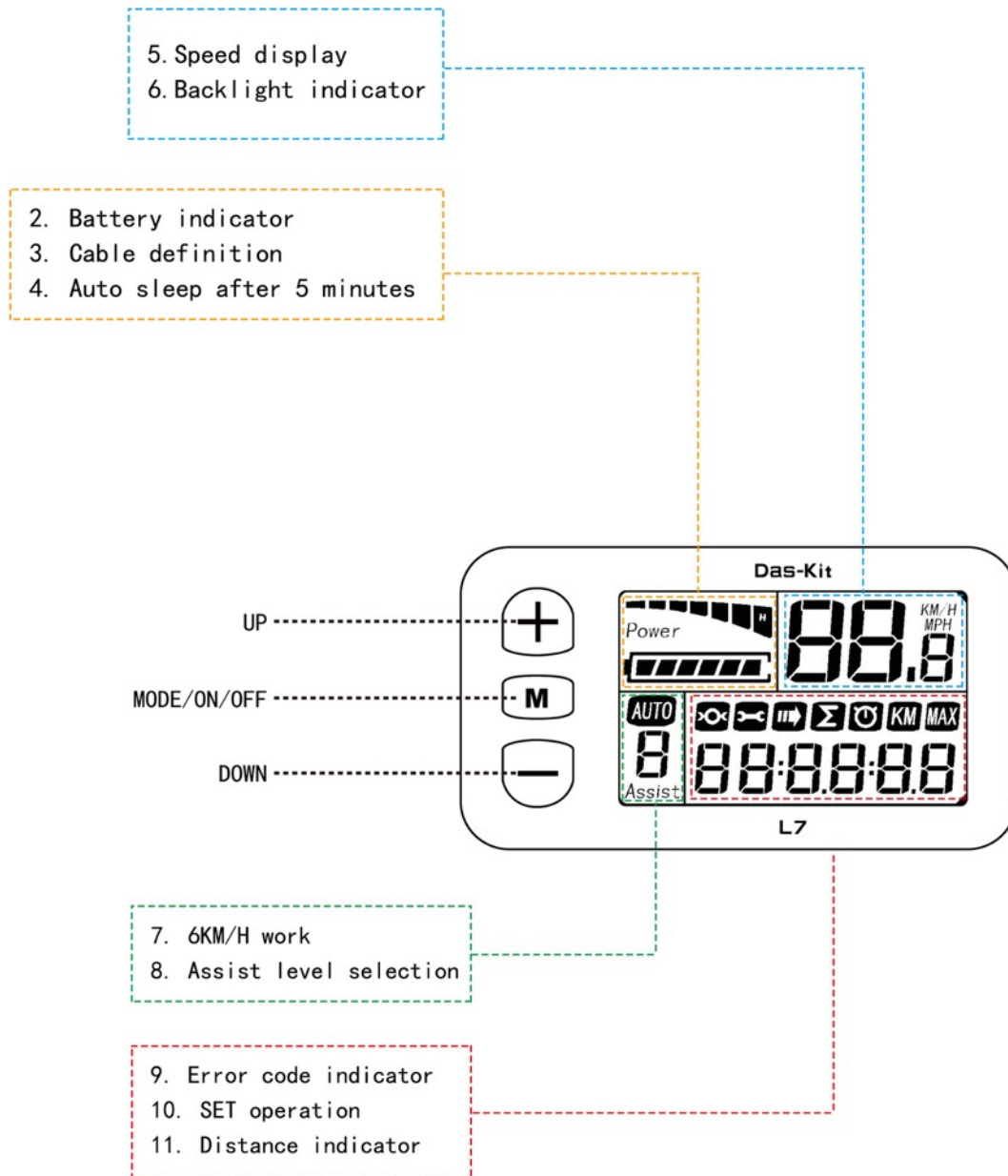

4.2 FULL VIEW AREA

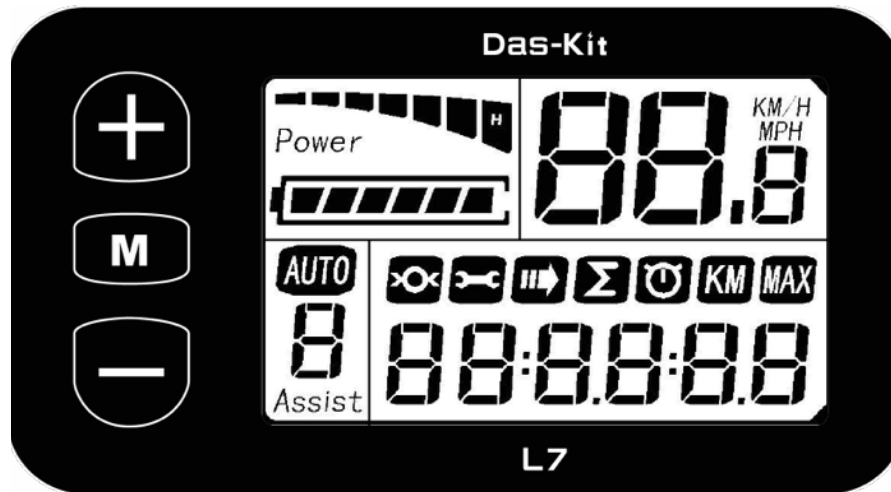

4.3 NORMAL VIEW AREA

The normal view area of the L7 is shown below.

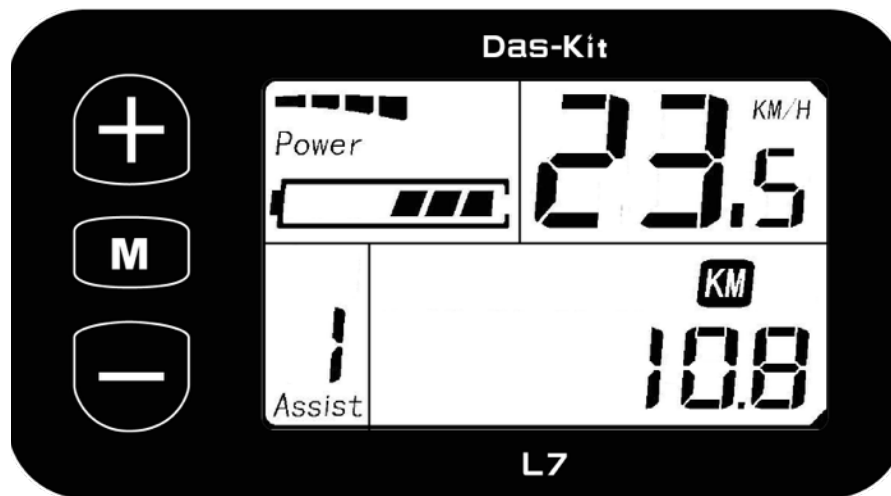

5. Normal operation

5.1 ON/OFF

Press M to activate the display. To turn the display off, press M for 2 seconds and the screen will go dark. If the display is powered off it will not consume any of the battery life. The leakage current is no more than 2 μ A.

※The panel will automatically power-off when speed is 0 km/h for 5 minutes.

5.2 CURRENT DISPLAY

This is the power indicator. It displays how much energy is being consumed by the system.



5.3 SPEED DISPLAY

This displays the current riding speed of e-bike. The speed display is as below.



5.4 BACKLIGHT INDICATOR

With the power on, press "+" for 1 second to turn on the backlight. Press it for 1 second again to turn off the backlight.

5.5 WALK MODE

Hold "-" for 2 seconds to enter into the walk mode. When the icon is lit, the e-bike is traveling at 4.5 mph. This is shown below.

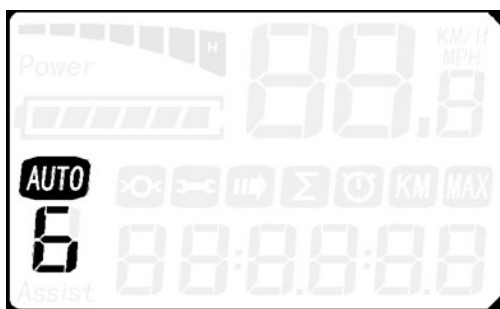

5.6 ASSIST LEVEL SELECTION

Click UP or DOWN to change the level of pedal assist you wish to receive. The levels range from 0-6, with 0 being the lowest and 6 being the highest. When the bike is powered on, the bike will automatically enter level 1. Please be aware that the levels loop: when you are at level 6 and press UP you will return to the lowest level and when you are on the lowest level and press DOWN you will enter the highest level.

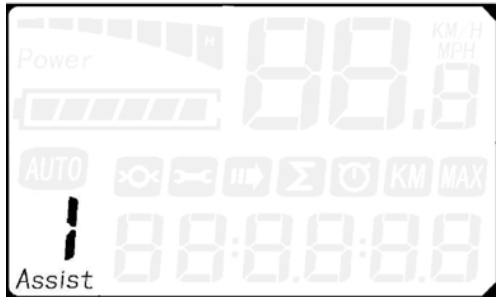

5.7 ERROR CODE DISPLAY

When the display comes up error, the icon and error code will flash together with 1Hz. Each error code is corresponding with the fault definition.

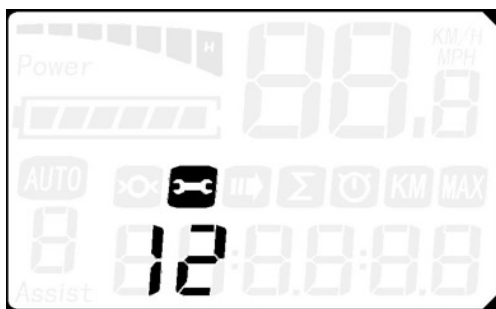

※ Only get rid of the error will clear the error code display.

The error code display is as below.

Error Code	Definition
0	normal
1	Current error or MOS damaged
2	Throttle error(detection after turning on)
3	motor without phase position
4	Hall error
5	Brake error(detection after turning on)
6	Under voltage
7	Motor stalling
8	communication controller receiving error
9	communication display receiving error

5.8 DISTANCE INDICATOR

With the display on, press M to switch the display information. This is organized into four categories: ODO, trip distance, riding time and max speed.



trip distance



riding time



max speed

5.8.1 ODO

The ODO records the driving mileage from use.



5.8.2 Trip distance

Trip distance records the driving mileage. As shown below.

Hold “+” for 5 seconds and the trip distance will be reset and skip to the trip distance interface.



5.8.3 Trip time indicator

The trip time records the riding time, as shown below.



5.8.4 Max speed

The max speed records the riding speed, as shown below.

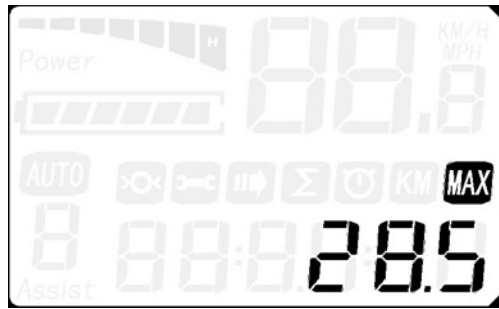

※Click  to start in turn show automatically.

5.11 BATTERY INDICATOR

When the battery capacity is high, the six battery segments are all lit. When the battery is low, the battery frame will flash. Flashing indicates that the battery is severely low and needs to be recharged immediately.

