

System Operation Manual

E3 Path+, Venture, Detour

This manual is meant to be read together with the owner's manual, also included with your bicycle. The owner's manual contains important safety and use information about your bicycle. Be sure to read both manuals before riding for the first time, or performing any assembly. If you did not receive an owner's manual, the most recent version can always be found online at www.CurrieTech.com.



CURRIE TECH™
Electric Bikes



Electric Bike Competence Center
North America

EBCC Technical and Customer Service: +1 800-377-4532

Contents

- Section 1** Electrical System Components 4
- Section 2** General information 8
- Section 3** Basics 10
 - Battery charging 10
 - Charging procedure* 10
 - Charge time* 10
 - Checking the battery's charge level* 10
 - Using the battery 11
 - Installing the battery* 11
 - Removing the battery.* 11
 - Turning the bike on and off.* 11
 - To turn the bike on...* 11
 - To turn the bike off...* 11
- Section 4** Riding and use 12
 - Getting ready to ride. 12
 - Riding the bike 12
 - Using the motor.* 12
 - Assist levels* 12
 - Throttle* 12
 - Cruise control.* 13
 - Using the brakes* 13
 - The display and control pad. 13
 - The display's cyclecomputer functions* 13
 - The display's electrical system functions.* 14
 - Assist level* 14
 - Battery level* 14
 - Maintenance information* 14
 - Control pad functions.* 14
- Section 5** Troubleshooting 15
 - Error codes 15
 - Charging issues 15
 - Misc issues 16
 - Lost key.* 16

Note

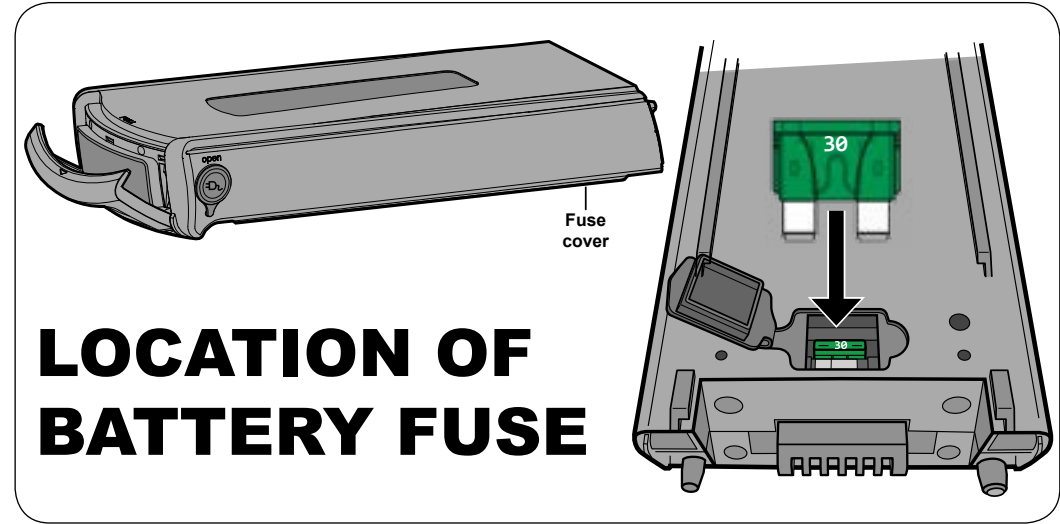

LOCATION OF BATTERY FUSE

Your bike now ships with the battery fuse installed for your convenience. We have started using an ultra low current draw BMS (battery management system) to keep the battery partially charged during shipping. You will want to top off that charge before riding (see page 10).

We use a standard 30-Amp automotive fuse readily available in auto supply stores. Should you ever need to remove and change it, this is where it is located. Page 16 in the troubleshooting section shows details on how to identify a blown fuse from a good one.

Electrical System Components

Battery and rack

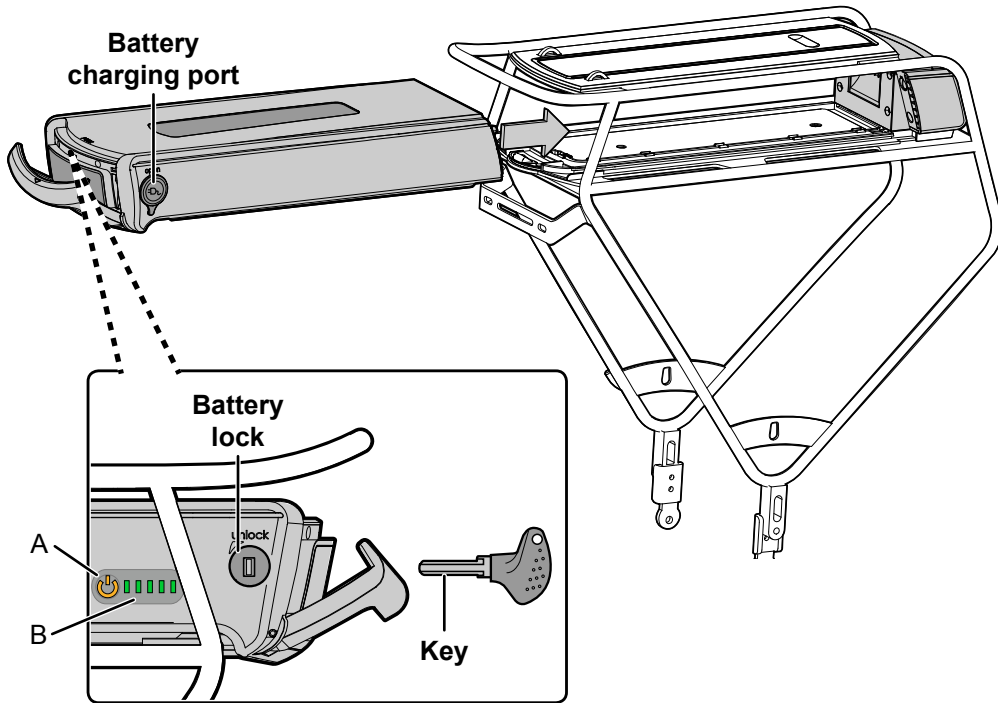

BATTERY BUTTONS

- A Battery power button
- B Battery level indicator

Control pad

CONTROL PAD BUTTONS

- A Assist level
- B Light
- C Power
- D Info
- E Cruise control

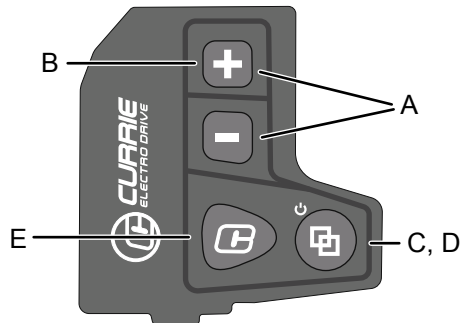

Operational details, see p.12-14

Display

DISPLAY FUNCTIONS

- A Ambient light sensor
- B Main display area
- C Speed
- D Odometer
- E Distance
- F Range
- G Maintenance indicator
- H Distance unit
- I Assist level indicator
- J Cruise control indicator
- K Low battery warning indicator
- L Battery level indicator

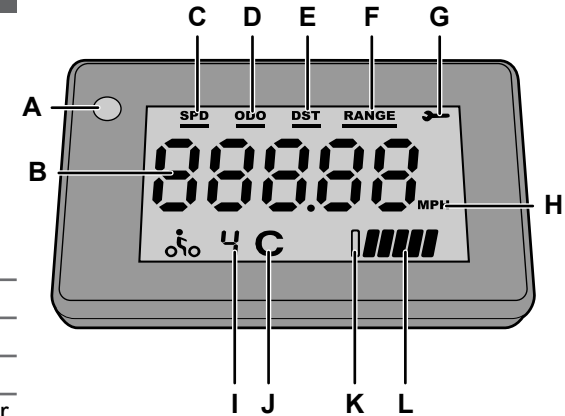

Throttle

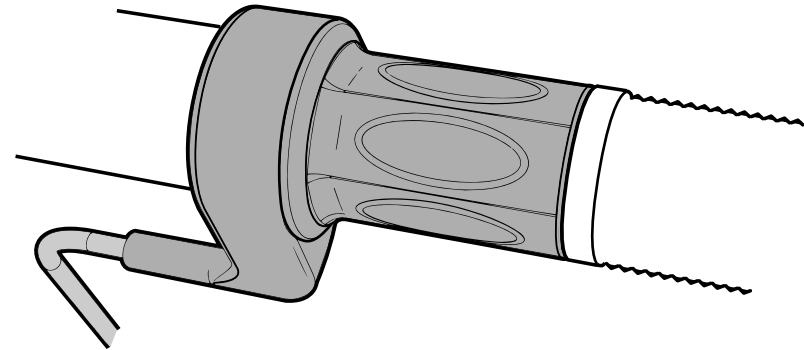

Battery charger

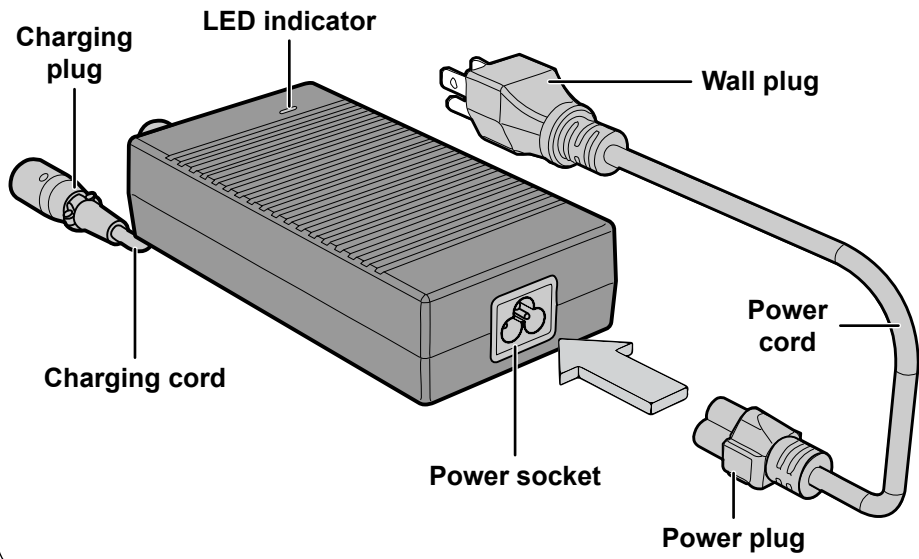

Rear wheel

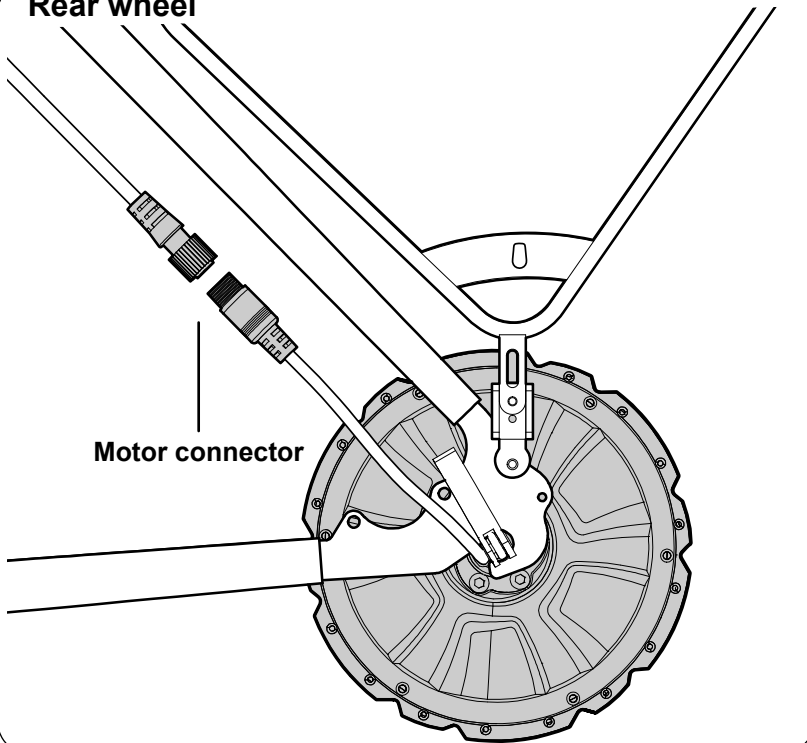

General information

USE RESTRICTIONS

Intended Use¹	Condition 2 (General purpose riding)
Minimum rider age	16 years
Maximum permissible weight²	110 Kg (242 lbs)

1. This bicycle is intended to be used under the guidelines of the stated condition, found in the intended use section of your owner's manual. Be sure to read this section of the owner's manual for more information.

2. Maximum permissible weight includes the weight of the rider (plus clothing, riding gear, etc), the weight of any added accessories, and any cargo being carried.

TECHNICAL SPECIFICATIONS

Motor	
Type	Rear hub drive
Rated power	500w
Peak torque	42 Nm
Battery	
Voltage	48V nominal
Capacity	8.8Ah
Energy	422Wh
Cycle life (expected)	~700
Charger	
Input voltage	110-240V AC (auto-sensing)
Frequency	50/60Hz
Input current	2.2A maximum
Charging voltage	54.6V DC (48V nominal)
Charging current	2.0A
Full charge duration	4-6 hours
Ride performance	
Top assisted speed	32 km/h (20 mph)
Range (expected)¹	25-35 miles
Control type	Throttle/pedal assist. Cadence sensor, speed sensor.

1. With normal pedaling; Contingent on terrain, rider weight, riding style, and other factors.

Basics

IMPORTANT: The owner's manual included with your bike contains most of the important safety and usage information about this bike, which is not included in this system operation manual. Be sure to read the owner's manual before you begin riding or working on your bike.

Battery charging

You should charge the battery fully before riding for the first time, following the instructions below. Be sure to check the section of your owner's manual discussing "Battery care & safety" for additional information.

Charging procedure

Connect the power cord to the battery charger. Plug the charging plug into the battery's charging port, then plug the wall plug into a wall outlet.

The charger should always be plugged first into the battery, then into the wall outlet.

Charging will begin immediately. The charger's LED indicator will light up to show its status.

LED	STATUS
Red	Charging
Green	Finished charging
Red (flashing)	Charging error; see "Charging issues" below

If the battery is attached to the bicycle, and the bicycle is turned on, the battery level indicator on the bike's display will show the current charge level. See "Turning the bike on and off" on page 11.

The battery does not have a "memory". This means that it can be charged at any time, or partially charged, without causing damage or decreasing performance.

Charge time

The amount of time needed to charge the battery varies based on the battery's charge level. A completely empty battery will take between 4 and 6 hours to charge. A battery at 50% may only need 2-3 hours to come to a full charge.

Checking the battery's charge level

Before riding, you should check the battery's charge level. If the battery is not fully charged, riding range will be reduced.

To check the battery's charge level, first turn on power to the battery and read the charge indicator right there, or if already powered on, you can read it on the display. Either way will show the battery's charge level.

Reading the display battery level indicator while riding, gives constantly refreshed data.

Each bar represents about 20% capacity:

BARS	BATTERY CHARGE
(low battery warning)	<5%
1	≤20%
2	~20– 40%
3	~40 – 60%
4	~60 – 80%
5	~80 – 100%

Using the battery

Installing the battery

First, make sure the battery is unlocked. If needed, unlock the battery by turning the key 45° counter-clockwise until it stops.

Then, slide the battery into the rack from the rear; the end of the battery will be flush with the battery receiver when fully inserted.

Finally, lock the battery in place by turning the key 45° clockwise.

You must lock the battery before riding the bike. If the battery is unlocked, it could fall out while you ride.

Removing the battery

To remove the battery, first unlock it, then pull it straight out the back of the rack.

Turning on the power

1. Press the power button on the battery first (see page 4). The battery level indicator will light up.

2. Next push the power button (⏻) on the control pad. The display will initialize, and turn on. Once the display is on, the bike is ready to ride.

To turn off the power

Typical way, using the handlebar controls: Press the control pad power button (⏻) two times, for 2 seconds each time. After the first press, the bike will enter assistance level 0, showing '0' on the display's assist level indicator (see "Assist levels" on page 12). After the second press, the bike will turn off and the display screen will go blank, as will the battery power indicator.

Alternative way, directly from the battery: Hold the battery power button for 2 seconds and confirm the LEDs are off.

Riding and use

Be sure to read the “Electric Bikes” section of your owner’s manual, and specifically pay attention to the sections on “Riding an electric bike” and “Riding a high-speed electric bicycle” before you ride for the first time.

Getting ready to ride

First turn the bike on, following the instructions in “Turning the bike on and off” on page 11 of this manual.

Mount the bicycle. Be sure you don’t accidentally twist the throttle, or turn the pedals; this could cause the bike to accelerate unexpectedly.

Riding the bike

Using the motor

The purpose of the motor is to gently augment the effort you put into riding the bike. When you pedal fast, the motor assists you more; when you pedal slowly, the motor assists you less.

So, to ride the bike, all you really need to do is pedal. The majority of the work of controlling the motor is done automatically.

There are, however, three other controls that affect how the motor runs: assist levels, the throttle, and cruise control.

Assist levels

Assist levels control *how much* power the motor will add to your pedaling. The assist level is shown on the display, and can be changed at any time using the **+** and **-** buttons on the control pad (see “Control pad functions” on page 14).

Levels 1–4 are increasing levels of automatic motor assist. Level 1 gives the least assistance; level 4 gives the most.

“T”, or “throttle-only” mode disables the

automatic motor assist, but leaves the throttle active. Simply twist the throttle to control the motor.

Level 0 disables motor assist completely. Other functions such as the cyclecomputer can still be used.

Throttle

The throttle can be used under certain conditions to override the automatic assist:

In “T”/throttle-only mode, automatic motor assist is disabled, and the throttle is always active.

In assist level 1–4, when moving under 10 km/h (6 mph), the throttle is always active, even without pedaling. This helps you get moving from a stop, and helps when navigating difficult terrain at low speed.

In assist level 1–4, when moving over 10 km/h (6 mph), the throttle is active as long as you are pedaling.

The throttle is never affected by assist level. Using the throttle, you always have control of up to 100% of the motor’s power.

Cruise control

While in “T”/throttle-only mode, cruise control can be turned on with the **Ⓢ** button:

First, pedal or use the throttle to reach your desired cruising speed. Hold the throttle in a position that maintains this speed, and press the **Ⓢ** button. You can then release the throttle, and the bike will hold its current speed, plus or minus about 3 km/h (2 mph).

Cruise control can be disabled at any time by pulling either brake lever, twisting the throttle, or by pressing the **Ⓢ** button again.

Cruise control will not function over 32 km/h (20 mph). If you turn on cruise control while traveling faster than 32 km/h, the bike will decelerate to 32 km/h and hold that speed.

Using the brakes

The brakes are integrated with the electrical system. When you pull the brakes, they not only slow the wheel like a normal bicycle brake, they also cut power from the motor.

See the “Brakes” section of your owner’s manual for more information.

The display and control pad

The display serves both as a cyclecomputer, displaying speed and distance information, and as an interface to the bike’s electrical system. The functions of the display are controlled by the control pad.

The display’s cyclecomputer functions

The display has four cyclecomputer functions. Switch between these functions using the **Ⓢ** button. The function’s information is displayed in the main display area.

CYCLECOMPUTER FUNCTIONS

SPD	Speed	The bicycle’s current speed
ODO	Odometer	The bicycle’s total mileage
DST	Trip distance	The distance covered during the current trip
Range	Remaining range	The estimated remaining range before the battery is empty

Distance and range are displayed in the units shown to the right of the main display area.

To reset the trip distance counter, hold **+** and **-** and **Ⓢ** on the control pad together for 10 seconds.

To reset the odometer, hold **+** and **-** and **Ⓢ** on the control pad together for 60 seconds.

The display's electrical system functions

The display shows information about the bike's electric assist, and gives the rider access to several important functions:

Assist level

The current assist level is shown on the display (assist level indicator).

Battery level

The battery level indicator shows the current charge level of the battery. Each bar represents about 20% capacity.

The low battery warning indicator lights up when the battery has less than 5% remaining charge.

Maintenance information





The maintenance indicator lights up when there is a system error. An error code shown on the display helps to diagnose the problem. See "Error codes" below.

Control pad functions

The control pad is used to control the various functions of the bike and display.

The control pad's four buttons perform the following functions:

CONTROL PAD FUNCTIONS

+	Increase assist level (1–4), or to switch to throttle only mode "T". Hold 2 seconds for backlight (and light set if installed).
-	Decrease assist level (4-1).
	Turn bike on, one quick press (turn on battery first, p.4)
	Change cyclecomputer display, quick presses to cycle through the options (after bike is on)
	Set power assist to 0, one 2 second press (no pedal or throttle assistance, just power for the display)
	Turn power off, one 2 second press (must be in assist level 0 first)
	Activate cruise control.

The display backlight and any attached headlight/taillight is also controlled by the ambient light sensor; they will automatically turn on in low light.

Troubleshooting

Error codes

SYSTEM ERROR CODES

In the event of a system error, these codes will appear on the display.

1	Motor internal error
4	Cadence sensor error
5	Motor speed sensor malfunction
6	Brake lever cut-off sensor malfunction
7	Throttle malfunction

Most of the time, these errors can be resolved easily by checking the wiring connections for the affected component. Call EBCC customer service, or see your dealer for more information.

Charging issues

ISSUE: Charger LED indicator flashes red

LED flashes red after charging for a while:

- ▶ Battery is not responding to charging.
 - The battery voltage is less than 25V, and does not rise above 25V after 30 minutes of charging.
 - The battery voltage is between 25V and 30V, and does not rise above 30V after one hour of charging.

Solution	▶ Reset charging by unplugging the charger from the wall outlet, then plugging it back in. If charging fails after a second attempt, the battery or charger may need to be replaced. Bring them to your dealer for inspection.
----------	--

- ▶ Battery has not finished charging after 10 hours.

Solution	▶ The battery may be damaged and should be inspected by your dealer.
----------	--

LED flashes red immediately after being plugged in:

- ▶ The polarity between the charger and battery does not match.

Solution	▶ The battery or charger may be damaged. Stop using the battery and charger immediately, and bring them to your dealer for inspection.
----------	--

▶ The output of the charger is short-circuited.

Solution ▶ Stop using the battery and charger immediately. Check for obvious external shorts on the charging plug and battery charging port. If no obvious short exists, the battery or charger may be damaged. Bring them to your dealer for inspection.

Other issues causing a flashing red LED:

▶ The temperature of the battery is too high to charge.

Solution ▶ Put the battery and charger in a cool place, then try charging again after a few minutes.

ISSUE: Charger LED indicator stays green when plugged into the battery.

▶ There is no connection between the charger and the battery.

Solution ▶ Check for damage: battery charging port, charging plug, charging cord, and power cord.
▶ There may be an internal problem with the battery or charger. Bring them to your dealer for inspection.

▶ The battery's voltage is too low to be charged.

Solution ▶ Check the battery's charge level as described in this document. If the battery will not turn on, the battery may be damaged and should be inspected by your dealer.

Misc issues

Lost key

If you have lost your keys, note your bike's serial number (located underneath the frame's bottom bracket) then call EBCC Technical and customer service at (800) 377-4532.

No power from battery

The battery has a user-replaceable fuse located at its base. The fuse is now preinstalled at the factory.

If the fuse is present but the bike does not power up, inspect the fuse; if it is blown out, it can be replaced with a standard 30-amp automotive fuse.

